



## Implementation of Smart Corn Planter (SCP) to Support Food Security in Agricultural Area Gondosuli Village Probolinggo Regency

Abdullah Iskandar Syah\*, Wahyu Tri Handoko, Moh. Zainul Falah, Ryan Kurniawan, Ahmad Hafid, Didik Dwi Prasetya  
Universitas Negeri Malang, Indonesia

✉ [abd.iskandar27@gmail.com](mailto:abd.iskandar27@gmail.com)

### Abstract

Gondosuli Village is located in Pakuniran, Probolinggo, East Java, and has an area of 11.66 km<sup>2</sup> (4.50 sq mi), consisting of agricultural land, settlements, public facilities, and mountain forests beneath Mount Rengganis. crops in Gondosuli village are dominated by rice and corn during the rainy season, and tobacco during the dry season. Corn has an important role as a commercial commodity in this village because it is used as animal feed, industrial raw materials, and also as a food ingredient. The process of planting seeds in Gondosuli village itself is still classified as using the traditional method where only using wood as a seed hole maker, and the seeds are inputted by human labor, and the distance between the seeds is only estimated by the farmer, in this way the seed planting process requires a lot of effort and time. big. A push corn planting tool or Smart corn planter is a tool used to grow corn efficiently and effectively on agricultural land. By using the Smart corn planter, farmers can grow corn quickly and more easily, and save effort and time. In addition, this tool can also help produce regular and even corn crops.

**Keywords:** Smart Corn Planter (SCP), Gondosuli Village, Support Food Security

### ARTICLE INFO

Article history:

Received

May 20, 20223

Revised

October 25, 2023

Accepted

November 07,  
2022

Published by  
ISSN

CV. Creative Tugu Pena  
2774-7077

Website

<https://attractivejournal.com/index.php/bce/>

This is an open access article under the CC BY SA license

<https://creativecommons.org/licenses/by-sa/4.0/>



### INTRODUCTION

Indonesia is an agricultural country that has various agricultural products such as rice, cassava, corn, and other crops that are important for national agriculture (Purwadi, Sasongko, & Hidayat, 2022; Purwantini dkk., 2020; Rahayu, Herliana, Dewi, & Rostaman, 2019; Rhofita, 2022; Suprapti & Moninthofa, 2018). Among various types of food commodities, corn is one of the main commodities after rice and plays a strategic role in the development of the agricultural sector and national economy (Haris & Falatehan, 2017; Masduki, 2019). Expanding the development of corn plants can make a positive contribution to the supply of food and industrial raw materials (Ashari, Abidin, & Tangahu, 2020; Husnarti, 2019; Noviana, Ardiani, & Astuti, 2021). Therefore, developing corn on a larger scale with higher production has the potential to increase farmers' income and the economy in the region (Firdaus & Fauziyah, 2020; Melia, Aldian, Pahlevi, Risqullah, & Oktaffiani, 2023).

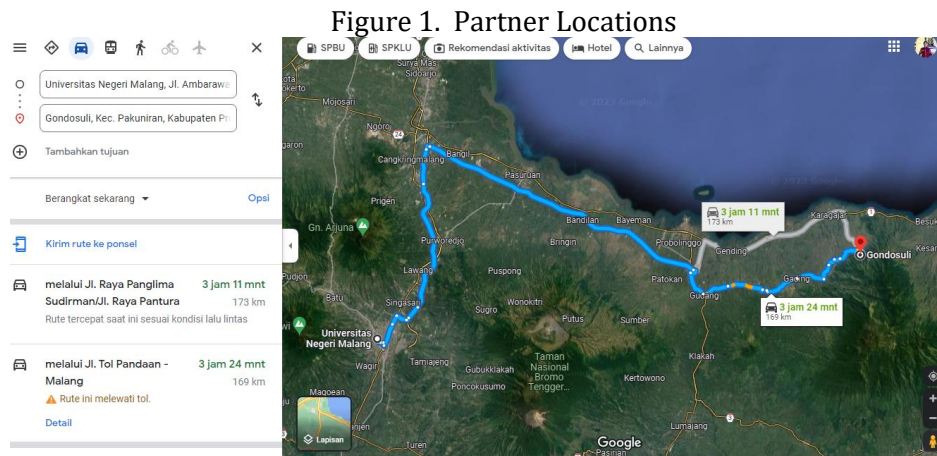

Gondosuli Village is located in the Pakuniran area, Probolinggo, East Java, with an area of 11.66 km<sup>2</sup> (4.50 mi<sup>2</sup>), which consists of agricultural land, settlements, public facilities, and mountain forests under Mount Rengganis (Sari, 2021). This area consists of 5 hamlets that stretch along the village, where each hamlet has one hamlet head and several RTs. Located on a plateau with small hills, this village has cool natural conditions and is strategic because it is traversed by the Kotaanyar-Pakuniran District road. This area is very suitable for building a villa because it has flat land contours and fertile soil conditions with a fairly good irrigation system.

Gondosuli Village has agricultural products which are dominated by rice and corn in the rainy season, and tobacco in the dry season. Corn has an important role as a commercial commodity in this village because it is used as animal feed, industrial raw materials, and also as food (BAKARA, 2022; Septiadi & Nursan, 2021). Around 21 percent of corn use in this area is used for food, 72 percent for feed, and 7 percent for other industrial sectors. Corn production in Gondosuli village has also experienced a significant increase in market demand in the last few decades.

**Figure 2. Gondosuli Agricultural Area**



Observing this, productivity in the field of corn farming must continue to be developed due to increasing market demand, to make it easier for corn farmers to carry out the process of planting seeds and maximize the time for farmers to plant corn seeds to

make it shorter and easier (He dkk., 2019; Hou, Wang, Ji, & Zhu, 2022; Liu & Yi, 2019; Wang, Wang, Wang, Mao, & Zhou, 2022; Zhao dkk., 2022).

The process of planting seeds in Gondosuli village itself is still classified as using the traditional method, which only uses wood as a hole for the seeds, and the seeds are input by human labor, and the distance between the seeds is only estimated by the farmer (Br Kabeakan & Manik, 2020; Jati, Purnomo, & Retnowati, 2022; Khairunnisa, Saidah, Hapsari, & Wulandari, 2021; Sirajuddin, 2021), in this way, the process of planting the seeds requires energy and time. which is big if you have to plant on a large area of land there can be a waste of land if farmers only calculate the distance between the seeds and this can result in incompatibility of growth in the corn seeds which will have an impact on the harvest period later.

This problem was conveyed by Mr. Muhammad's partner as the village head of Gondosuli District. Pakuniran District. Probolinggo. due to the lack of adequate equipment in the process of planting seeds which takes a long time and land is wasted because farmers only calculate the distance between seeds so they need to increase efficiency and productivity in planting corn.

## **METHOD**

Based on the results of discussions and literature studies with partners, the solutions offered together with partners are prepared with the following problem-solving framework:

1. Create a smart corn planter that functions to plant and water corn seeds automatically so that it can increase efficiency and productivity in planting corn.
2. Design of a smart corn planter for planting corn seeds.
3. Assembly and installation of a smart corn planter for planting corn seeds in the area in Gondosuli Village, District. Pakuniran Probolinggo.
4. Smart corn planter testing for planting corn seeds. This test is carried out to determine whether the smart corn planter is installed correctly and functions as intended.
5. Technology transfer is carried out through a training program on using a smart corn planter for planting corn seeds in Gondosuli Village, Pakuniran District, Probolinggo Regency.
6. Evaluation.

For problem-solving and solutions offered to Gondosuli Village partners, Kec. Pakuniran district. Probolinggo, a solution framework was prepared. The method used in this service is, first, by creating a framework. The framework will explain the sequence that will be implemented, followed by training on the installation and maintenance of the smart corn planter. In general, the implementation of this community service is as follows:

1. Observation, this activity aims to find partner needs, to get the results of the observation the team goes directly to the partner location, conducts interviews directly with partners, and carries out documentation.
2. Preparation and design of the smart corn planter, this activity is carried out for one month, including agreements with partners, and preparation of activity schedules.

Figure 3. Smart corn planter design

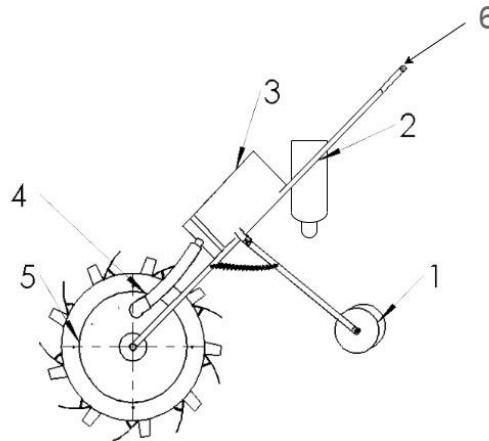

Design planning and system design calculations before being implemented in the field by considering the location and observation results that have been obtained using the following process.

- a. Prepare the necessary materials, such as iron pipes, wheels, plowshares, and seed containers.
- b. Cut the steel pipe to the desired size to form the frame of the push corn planting tool. Install the wheels on the back of the frame and the plowshares on the bottom of the frame.
- c. Make a seed container that can be attached to the front of the frame. Seed containers can be made of plastic or wood according to needs.
- d. Install all tool components neatly and safely so that the tool can function properly when used.
3. Smart corn planter training and maintenance. This activity is carried out directly on location, with the following steps.
  - a. Training on using the smart corn planter. Partners will be guided to be able to use and maintain the smart corn planter. This mechanism will be carried out directly in the field.
  - b. Shows how to use tools correctly and safely. explains how to load seeds, operate tools, and plant corn using these tools.
  - c. Allow training participants to try using the tool directly. Monitor and provide advice if there are errors in using the tool (Falah, Handoko, Syah, Azizah, & Gumilar, 2023; Falah, Syah, dkk., 2023).
  - d. Explains the benefits of using a push corn planting tool, such as saving time and energy, as well as increasing productivity.
4. Performance testing. The system performance is tested to find out whether the solar panel installation can work properly.
5. The handover of the smart corn planter was carried out by team representatives and partners.
6. Documentation. This activity can be carried out from start to finish using a camera or video.
7. Evaluation.
  - a. Monitor tool use regularly to ensure the tool is still in good condition and functioning properly.
  - b. Provide feedback to tool users to improve long-term use of the tool.
  - c. Evaluate the effectiveness of using tools in increasing productivity and efficiency in planting corn.

## RESULT AND DISCUSSION

The community service program entitled "Implementation of Smart Corn Planter (SCP) to Support Food Security in Agricultural Area Gondosuli Village, Pakuniran District Probolinggo Regency" produced significant results with broad implications. The program's main goal is to address food security challenges by introducing advanced agricultural technologies to simplify the maize-growing process, optimize resource utilization, and increase the overall crop yields of local farming communities.

Figure 4. (a) and (b) Implementation of Smart Corn Planter (SCP)



(a)



(b)

The implementation of Smart Corn Planter (SCP) technology marks an important milestone in this effort. By integrating state-of-the-art planting machines with modern sensor systems, SCP enables precise and efficient corn planting. The ability to adjust planting depth and spacing according to soil conditions significantly increases planting accuracy and reduces potential waste. This not only results in optimal land use but also increases corn yields, which directly contributes to village food security.

In addition, this program has a wider impact on local communities beyond the application of technology. With the introduction of SCP technology, farmers in Gondosuli Village are exposed to innovative practices that minimize labor-intensive processes and increase agricultural productivity. This exposure is important to equip farmers with valuable knowledge and skills that can empower them to implement more efficient and sustainable farming practices in the long term. In addition, the involvement of this community service program encourages collaboration between farmers, fosters a joint

learning environment, and encourages the exchange of insights and experiences related to modern agricultural techniques.

Figure 5. Handover of Smart Corn Planter (SCP) and Group Photo



The combination of modern technology and community involvement has the potential to have a significant impact on local food production, thereby bringing progress towards food self-sufficiency. As Gondosuli Village continues its journey towards increasing food security, this project serves as a model, highlighting the symbiotic relationship between technology adoption, community engagement, and sustainable agricultural practices.

## CONCLUSION

In conclusion, the application of Smart Corn Planter (SCP) technology as an effort to increase food security in the agricultural landscape of Gondosuli Village, Pakuniran District, Probolinggo Regency, has demonstrated the transformative potential of innovative solutions in overcoming urgent challenges. By introducing advanced planting machines equipped with real-time monitoring capabilities and adjustable planting parameters, the project significantly improves planting accuracy and optimizes resource utilization. The positive results will not only be increased corn yields, as the project also facilitates knowledge transfer and skills enhancement among local farmers, empowering them to adopt modern farming practices. This engagement fosters a sense of collaboration and shared learning, further strengthening the impact of technology. As the village progresses in efforts to increase food security, this initiative is an exciting example of how the harmonious integration of technology, community engagement, and sustainable agricultural practices can produce lasting positive change.

## ACKNOWLEDGMENTS

A big thank you to the Institute for Research and Community Service (LP2M) State University of Malang for providing support, funding, and opportunities to the service team through non-APBN UM funding Source of Funds 2023 Fiscal Year Number 5.4.1/UN32/KP/2023. Thanks are also expressed to the partners of Gondosuli Village, Pakuniran District, Probolinggo District who have permitted the team to carry out this activity. Don't forget to express your thanks to all participants in this activity for their cooperation so that this activity can run well.

## REFERENCES

Ashari, U., Abidin, Z., & Tangahu, M. R. (2020). Analisis SWOT dalam Menentukan Strategi Pemasaran Emping Jagung IKM Al-Fazal Kabupaten Bone Bolango. *Jurnal Ekonomi Pertanian dan Agribisnis*, 4(4), 794–807.

- BAKARA, I. M. (2022). *Analisis Pendapatan, Nilai Tambah Dan Distribusi Nilai Tambah Serta Kelayakan Usaha (Break Even Point) pada Industri Rumah Tangga Pengolahan Jagung Marning (Jagung Goreng)*. Diambil dari <http://repository.uhn.ac.id/handle/123456789/8120>
- Br Kabeakan, N., & Manik, J. (2020). Kepuasan Dan Loyalitas Petani Jagung Menggunakan Benih Bersubsidi Di Desa Laubaleng Kecamatan Laubaleng Kabupaten Karo. *Jurnal Agrica*, 13(2), 124–135.
- Falah, M. Z., Handoko, W. T., Syah, A. I., Azizah, F. Z., & Gumilar, L. (2023). IMPLEMENTATION OF SMART FARMING BASED SOLAR CELL SYSTEM IN HYDROPONIC IN THE AGRICULTURAL AREA OF BLITAR VILLAGE. *Community Development Journal: Jurnal Pengabdian Masyarakat*, 4(4), 7015–7020.
- Falah, M. Z., Syah, A. I., Handoko, W. T., Laila, N. N., Faridah, F. N., & Muladi, M. (2023). Implementation of an IoT-Based Smart Water System as a Means in Monitoring the Use of Consumer Water Debit Using Photovoltaic in Seboro Village Probolinggo. *Bulletin of Community Engagement*, 3(2), 88. doi: 10.51278/bce.v3i2.864
- Firdaus, M. W., & Fauziyah, E. (2020). Efisiensi Ekonomi Usahatani Jagung Hibrida di Pulau Madura. *Agriscience*, 1(1), 74–87.
- Haris, W. A., & Falatehan, A. F. (2017). Analisis peranan subsektor tanaman pangan terhadap perekonomian Jawa Barat. *Journal of Regional and Rural Development Planning (Jurnal Perencanaan Pembangunan Wilayah dan Perdesaan)*, 1(3), 231–242.
- He, X., Ding, Y., Zhang, D., Yang, L., Cui, T., & Zhong, X. (2019). Development of a variable-rate seeding control system for corn planters Part II: Field performance. *Computers and Electronics in Agriculture*, 162, 309–317.
- Hou, S., Wang, S., Ji, Z., & Zhu, X. (2022). Design and Test of the Clearing and covering of a minimum-tillage planter for corn stubble. *Agriculture*, 12(8), 1209.
- Husnarti, R. Y. (2019). Manajemen Rantai Pasok Kerupuk Ubi Kayu Sebagai Agroindustri Berbasis Pangan Lokal di Kabupaten Lima Puluh Kota. *Menara Ilmu*, 13(11). Diambil dari <https://www.jurnal.umsb.ac.id/index.php/menarailmu/article/view/1641>
- Jati, D., Purnomo, S. D., & Retnowati, D. (2022). Minat Petani Jagung Dalam Pembentukan Kelompok Tani Di Desa Sokawera, Somagede, Banyumas. *Ekonomikawan: Jurnal Ilmu Ekonomi dan Studi Pembangunan*, 22(2), 139–149.
- Khairunnisa, N. F., Saidah, Z., Hapsari, H., & Wulandari, E. (2021). Persepsi Petani Tentang Peran Penyuluh Pertanian Dalam Peningkatan Pendapatan Petani Jagung Hibrida. *Mimbar Agribisnis*, 7(1), 486–498.
- Liu, K., & Yi, S. (2019). Design and experiment of seeding performance monitoring system for suction corn planter. *International Journal of Agricultural and Biological Engineering*, 12(4), 97–103.
- Masduki, M. (2019). Diversifikasi Inovatif Olahan Jagung Sebagai Penyokong Perekonomian Masyarakat Desa Tagungguh. *Jurnal Ilmiah Pangabdhi*, 5(1). Diambil dari <https://journal.trunojoyo.ac.id/pangabdhi/article/view/5154>
- Melia, F., Aldian, F. M., Pahlevi, M. S. F., Risqullah, R. N. I., & Oktaffiani, S. (2023). PERAN PEMERINTAH DALAM MENINGKATKAN VOLUME EKSPOR JAGUNG. *JURNAL ECONOMINA*, 2(1), 269–284.
- Noviana, G., Ardiani, F., & Astuti, Y. T. M. (2021). Budidaya Caisim dan Pakcoy Teknik Vertikultur dalam Rangka Peningkatan Kemandirian Pangan. *Jurnal Ilmiah Pangabdhi*, 7(2), 86–88.
- Purwadi, P., Sasongko, P. E., & Hidayat, R. (2022). Pendampingan Kelompok Tani Hutan Desa Panglungan Dalam Pembibitan Porang (*Amarphophallus onchophillus* Prain). *Jurnal Ilmiah Pangabdhi*, 8(2), 108–116.

- Purwantini, A. H., Hermawan, C. A., Nugraheni, D. S., Annisa, M. R., Kurniawan, R., & Tanafi, D. I. (2020). PPMT Pemberdayaan KWT Sakinah Dusun Gales, Kabupaten Magelang Guna Mewujudkan Kemandirian Ekonomi Keluarga. *Jurnal Ilmiah Pangabdhi*, 6(2), 122–127.
- Rahayu, A. Y., Herliana, O., Dewi, E. M., & Rostaman, R. (2019). Pengembangan Budidaya Kopi Robusta Organik pada Kelompok Tani Sido Makmur Desa Pesangkalan Kabupaten Banjarnegara. *Jurnal Ilmiah Pangabdhi*, 5(2), 103–109.
- Rhofita, E. I. R. (2022). Optimalisasi Sumber Daya Pertanian Indonesia untuk Mendukung Program Ketahanan Pangan Dan Energi Nasional. *Jurnal Ketahanan Nasional*, 28(1), 82–100.
- Sari, L. N. (2021). *Analisis Skala Produksi Jangka Pendek UD Karya Mebeler Desa Gondosuli Kecamatan Pakuniran Kabupaten Probolinggo pada Masa Pandemi Covid-19* (PhD Thesis, Fakultas Ekonomi dan Bisnis Islam Jurusan Ekonomi Islam Program Studi ...). Fakultas Ekonomi dan Bisnis Islam Jurusan Ekonomi Islam Program Studi ... Diambil dari <http://digilib.uinkhas.ac.id/id/eprint/6766>
- Septiadi, D., & Nursan, M. (2021). Analisis Pendapatan Dan Kelayakan Usahatani Jagung di Kabupaten Dompu. *Agroteksos*, 31(2), 93–100.
- Sirajuddin, Z. (2021). Diversifikasi pendapatan petani jagung di Desa Isimu Raya, Kabupaten Gorontalo. *Manajemen Agribisnis: Jurnal Agribisnis*, 21(2), 141–149.
- Suprapti, I., & Moninthofa, A. H. (2018). Pendampingan kelompok tani di kabupaten pamekasan untuk pengembangan entrepreneur Agribisnis Jagung Madura. *Jurnal Ilmiah Pangabdhi*, 4(2). Diambil dari <https://eco-entrepreneur.trunojoyo.ac.id/pangabdhi/article/view/4931>
- Wang, B., Wang, Y., Wang, H., Mao, H., & Zhou, L. (2022). Research on accurate perception and control system of fertilization amount for corn fertilization planter. *Frontiers in Plant Science*, 13, 1074945.
- Zhao, H., Zhang, D., Yang, L., Cui, T., Song, W., He, X., ... Dong, J. (2022). Optimal design and experiment of critical components of hand-pushing corn plot precision planter. *Agriculture*, 12(12), 2103.

---

**Copyright Holder :**

© Abdullah Iskandar Syah et al., (2023).

**First Publication Right :**

© Bulletin of Community Engagement

**This article is under:**

CC BY SA