



Manufacture and Analysis Performance of Injection Device System 4 Stroke Engine Against Emissions

Bagus Dwi Cahyo¹, Bambang Irawan²

^{1,2} Politeknik Negeri Malang, Indonesia

 bambang.irawan@polinema.ac.id*

Abstract

Electronic fuel injection is a mechanism of fuel injection by electronic in to combustion chamber with Electronic Control Unit (ECU) for process control enter and burning air-fuel mixture. Fuel injection system is a development of natural suction system which next five years will no longer be produced. Natural suction system produces high emissions due to inhomogenous the air-fuel mixture. The natural suction system still widely used and its possible that in the next five years it will no longer be produced. The purposes of the study are manufacture and redesign injection intake manifold by sand casting with aluminium material as a replacement of natural suction fuel system with Arduino AT-Mega 2560 as a microcontroller with crankshaft position sensor, unit sensor (manifold absolute pressure, throttle position, intake air temperature) to produce efficient emissions. The study method of analysis data for making conclusion is quantitative experiments two-way ANOVA with two independent variables are (1) intake manifold type and (2) fuel flow rate volume against emissions. The study results are manufacture of injection intake manifold by using the sand casting method with aluminium material is simple method for changes to the injection system against emissions with value CO 14,27%, HC 212 ppm, CO₂ 12,133 % and O₂ 6,270 %, intake manifold type and fuel flow volume significant against emissions.

Keywords: Injection Device System, Intake Manifold, Redesign, Emissions

ARTICLE INFO

Article history:

Received

December 15,
2023

Revised

February 15,
2024

Accepted

March 06, 2024

Published by

ISSN

Website

This is an open access article under the CC BY SA license

<https://creativecommons.org/licenses/by-sa/4.0/>



CV. Creative Tugu Pena

2963-6752

<https://attractivejournal.com/index.php/ajse>

INTRODUCTION

The based of study is a gasoline engine with carburetor system are still used. The electronic fuel injection system is a development of natural suction or carburetor system. The carburetor mechanism to generate high emission. Besides that the part of carburetors system possible on the next five years will no longer be produced.

Emission has occurred when the engine has finished the cycle. In the 4 stroke engine, compression suction produce emissions. From totally of energy that 20% combustion for power and over 80% lost due to friction. Fuel is formed

Hydro Carbon (HC) component, with HC will not burn in the combustion chamber if no air. Air consist of 21% Oksigen (O₂), 78 Nitrogen (N₂) and 1 % other gaz. The perfect combustion reaction shown at fig. 1. Combustion engine is perfect if, comparison of air and fuel is 15:1. HC will be react with O₂ then produce water steam and carbon dioxide (CO₂), heat outputs, and cylinder pressure. But at the other condition, nitrogen will be react with O₂ and produce nitrogen oxides that is a pollutant as shown at figure 2[5].

Figure 1. Perfect Combustion Chemical Reaction [5]

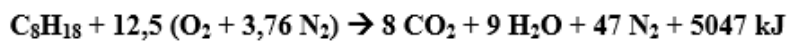
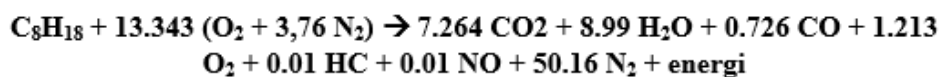

Figure 2. Imperfect Combustion Chemical Reaction[5]



Over air in the combustion chamber will be increase HC and NO which can be dangers for health and human life. But, if over fuel can be the fuel not burn perfect and increace high CO gas. The high CO can be decrease Oksigen in people bloods decrease and died [5].

There are more reasearch for solve this problem. Changing fuel injection by treating air intake with throttle opening with control the throttle valve by search best open throttle 10 degrees until 60 degrees[15].

Replacement carburetor system with injection system other existng system at 110 cc motorcycle, to generate eficient fuel consumption beside carburetor system. The electronic system of injection using by electronics existing system[9]. Replacement of injection system at prototype 4 stroke engine with modification pyston chavity design and geometris position to generate perfect air-fuel mixture[1]. Comparison carburetor system and injection system with direct injection contruction system at 750rpm until 1500rpm to generate low emission and increase atomization air-fuel mixture[7]. Change injection duration time at motorcyle 156 cc with increase duration time injection by using hall effect sensor to generate low emission 70%[17]. Modification design of intake manifold with CFD simulation that result manifold bending in close 180 degrees is generate perfect air-fuel mixture[26].

Emission can be solve with make perfect air-fuel mixture. Injection system work by using electronic system for air intake and burning process. Consist of electronic system are microcontroller, sensor and actuator. Microcotnroller have function to receive data from sensor and process data to be command signal to actuator. In injection system has a microcontroller, sesnor CKP, unit sensor (MAP, IAT and TP) and Injector. CKP sensor and unit sensor are work for generate perfect air-fuel mixture. CKP sensor detect compression time for burning air-fuel mixture properly. Injector will injecting fuel in to intake manifold when the CKP detect the crankshaft position at the suction stroke. Therefor, injection system with electronic system can be decrease emissions and has a perfect air-fuel mixture.

For the place injector in intake manifold is different. The different of carburetor intake manifold and injection is on the back. The injection intake manifold has a place for injector. Intake manifold made of iron or aluminium material. The process of build intake manifold by sand casting with iron or aluminium material. Metal casting is beginning from identification of product, then designing the product. After that, make a pattern of mold casting, then the aluminium or iron liquid entered in to sand mold. After cold, clean the product from sand then finishing by using turning and drilling machine for hollow out parts[30]. There is reserch about manufacture of intake manifold with the long intake increase from 150 mm in to 210 mm by using pattern with fiberglass and epoxy material. The beginning of process manufacture is designing with CAD solidwork, then the fiberglass intake ready, the experiment are generate intake manifold with light and strong material besides that produce high torque and high air flow in modification intake manifold[28]. According the several research there are still problem, so this research is developed with title manufacture and analysis injection system device at 4 stroke engine againts emission. The purposes of the research are manufature and redesign injection system device by sand casting with aluminium material as a replacement natural suction or carburetor system, installation injection system with redesign intake manifold electronic system and generate low exhaust emissions.

METHOD

The research flow chart during the process is shown in figure 3.

Figure 3. Reserch Flow Chart

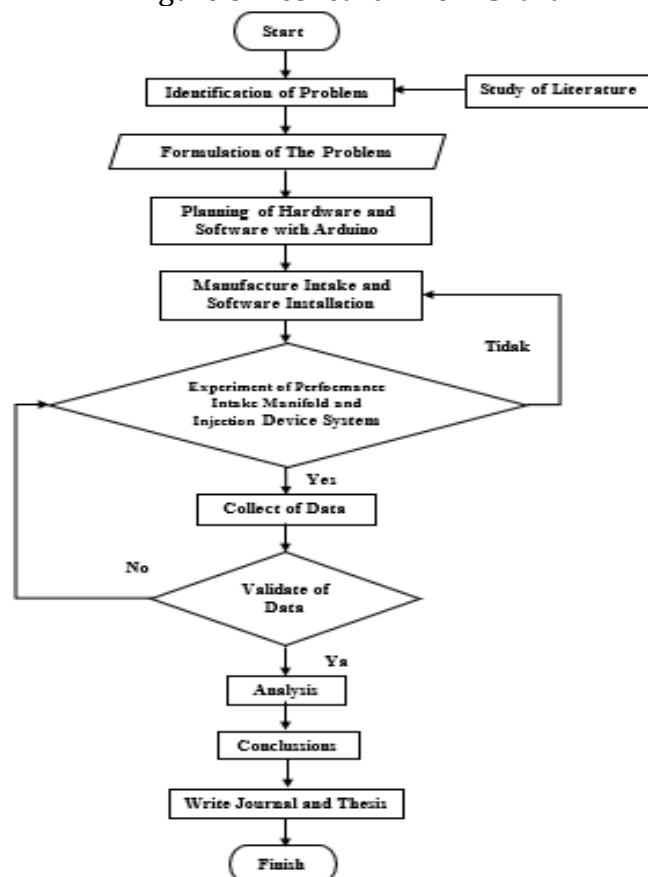

The experimental method is analysis variance two way anova to determine the conclusions. The experimental variable required for implementation and experimental data collect. Independent variable againts dependent variable, on this study there are two variables independent, type of intake manifold fuel system (Intake manifold carburetor and redesign injection intake manifold) and flow rate volume of fuel (0,05642 ml/s, 0,06407 ml/s, 0,07886 ml/s). Dependent variable affected by independent variables, on this study emissions as a dependent variable. Control variable is a controller on each experiments, engine rotation speed (750rpm, 1000rpm, 2000rpm, 3000 rpm, 4000 rpm dan 5000 rpm) as a variable control.

Material

In this research for manufacture of intake manifold made by aluminium material. When the intake manifold was finished, intake manifold was installing with the other components, among others are throttle body, crankshaft position sensor, unit sensor (Manifold Absolute Pressure, Intake Air Temperature, Throttle Position), and injector. The all components was controlling by Arduino AT-Mega 2560 as a microcontroller.

Methods

Manufacture and redesign injection intake manifold with sand casting method is the next experiment. Experiment using aluminium as a material to make injection intake manifold.

Figure 4. Process Redesign Injection Intake Manifold (a) Identification, (b) Designing by Catia V5, (c) Make a Mold with Wood Material, (d) After being Molded by Sand Casting with Aluminium Material

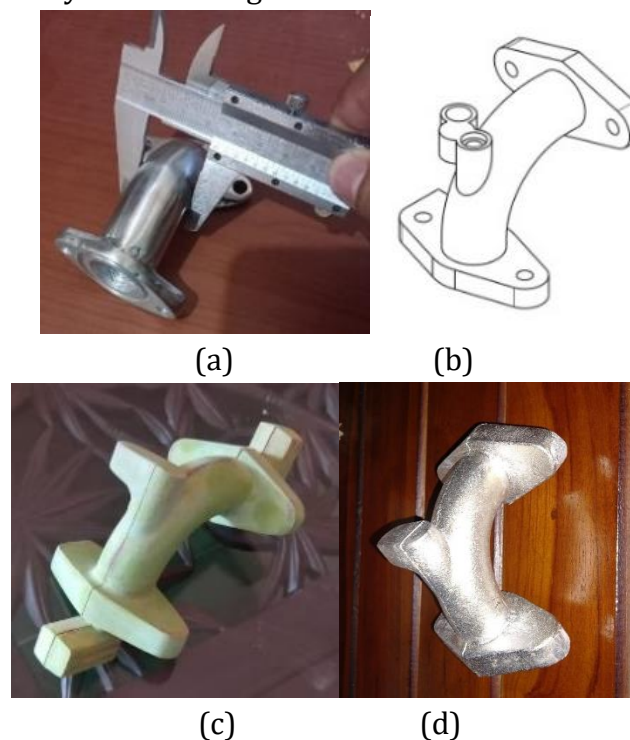
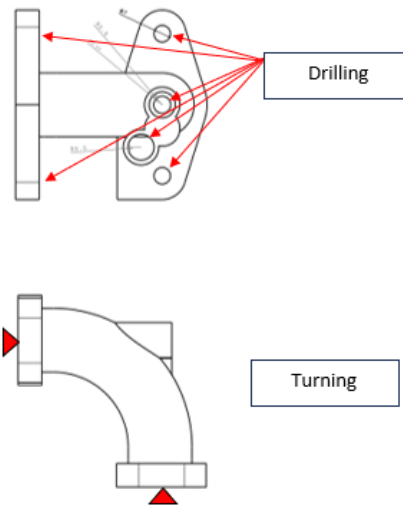

Figure 4 shown that starting manufacture with identification and redesigning of injection intake manifold by Catia V5, then make molds with wood material. The wood material was drawing 1:1 scale with 2 mm tolerance. The mat entered in to silica sand to make pattern with arrange the cavity for the molten aluminium enter to the sand cavity. After the molten aluminium was poured, the intake will be harden until cold aluminium.

Figure 5. Part of The Intake Manifold that Needs Turning and Drilled



Remove the sand in around intake manifold after cold aluminium, then the intake manifold was turning on the line intake and drilling as a figure 5. After intake manifold finish, intake manifold was installed with electronic system by crankshaft sensor, unit sensor, injector and Arduino AT-Mega 2560 as a microcontroller.

Figure 6. Experiment with Gas Analyzer



The experiment was carried out with 107,2 cc of engine specification. The experiment attempt to collect flow rate volume of fuel system data with 100 ml of gasoline RON 92 will be used up in a unit of time. Based of results of flow rate volume of fuel system from the size of diameter mainjet in carburetor, there are 0,072 mm, 0,075 mm and 0,078 mm, with every experiment when the tank is empty, then 100 ml gasoline entered in to the tank, then the engine was turned on at idle (750rpm). Time was recorded until the engine was turn off. From the result of experiment, the flow rate volume of fuel can be calculated using the formula in Eq (1).

Table 1. Calculation of Experiment Fuel Flow Rate to Injection Duration by Using Formula 1

Mainjet Carburetor Diameter (mm)	Injection Duration (ms)	Fuel Flow Rate Volume (ml/s)	Fuel Volume (ml)	Time Average (s)
0,0072	0,000056432	0,05642	100	1772,33
0,0075	0,000064075	0,06407	100	1560,67
0,0078	0,000078997	0,07886	100	1268,00

The final experiment is emissions experiment with compare intake manifold carburetor between redesign injection intake manifold. The experiment method is equalize of the flow rate volume of fuel carburetor and injection. The experiment using gas analyzer for shown the result of emissions with control variabel on every independent variables. Three repetitions of the experiment for each variables. After the data collected, to determine conclusions the results will be process by two way anova.

RESULTS AND DISCUSSION

In some condition, independent variable will take the result of dependent variable with a combination variable control that's record emissions. The type of manifolds are natural suction or Redesign injection will be compared with the result is emissions. The volume fuel flow rate of the both of manifold will be equalized. With the same volume fuel flow rate, will be different produce emissions. The data will be collect by 750rpm until 5000 rpm the speed of rotation engine. Besides that, redesign of carburetor intake manifold to injection is simple manufacturing and as a replacement for conventional systems by replacing and installing without changing the main construction or buying a new injection engine. The redesign injection maanifold was installing by designed with build part at the back add the place of injector. The beginning part was connected throttle body and the end connected to cylinder head of engine.

Figure 7. Installation Electronic System in to Inejction Intake Manifold

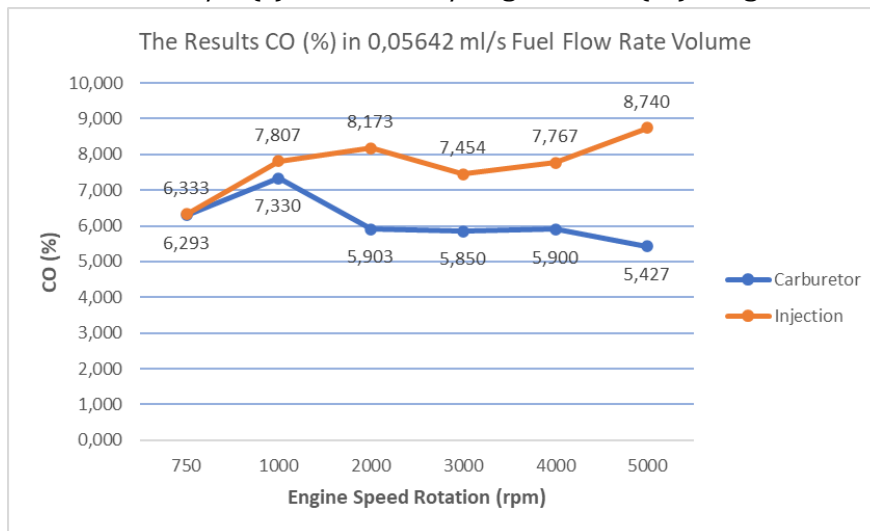

Figure 8. Control Injection Duration by Code Arduino

```
const unsigned long injectionInterval = 564/1000000; (a)
const unsigned long injectionInterval = 640/1000000; (b)
const unsigned long injectionInterval = 788/1000000; (c)
```

The process of installation injection intake manifold apply electronic system by using sensor CKP, unit sensor, injector and arduino AT-Mega 2560 as a microcontroller for fuel injection. Duration of injection can be adjusted and equated with calculation of flow rate volume of fuel carburetor like shown fig. 7. Fig 8. shown that code arduino can change the duration with mili second unit. Duration 564/1000000 for 0,0564 ml/s, 640/1000000 for 0,0640 ml/s and 788/1000000 for 0,0788 ml/s. The result of againts intake maifold type and fuel flow rate volume to emission shown at the figure of diagram.

Figure 9. Type of Intake Manifold and Fuel Flow Rate Volume (a) 0,05642 ml/s, (b) 0,0640 ml/s, (c) 0,07886 ml/s againts CO (%) Diagram.



(a)

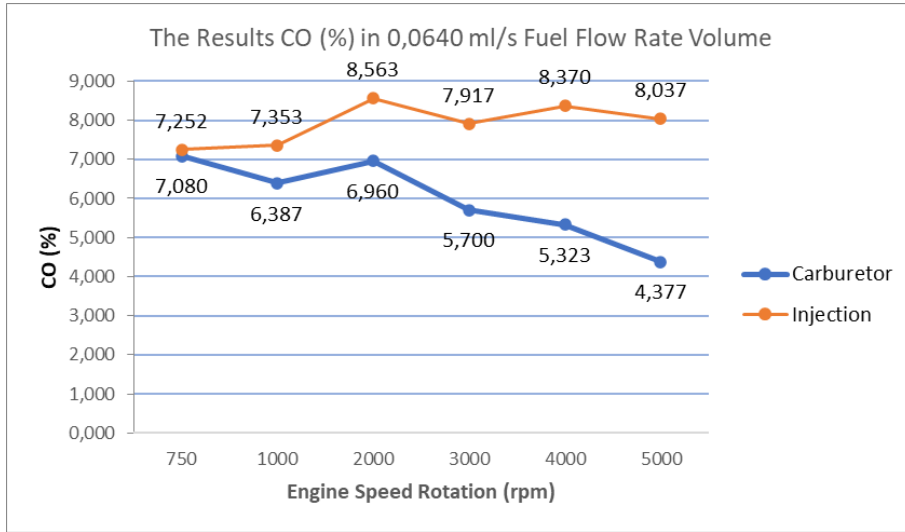

(b)

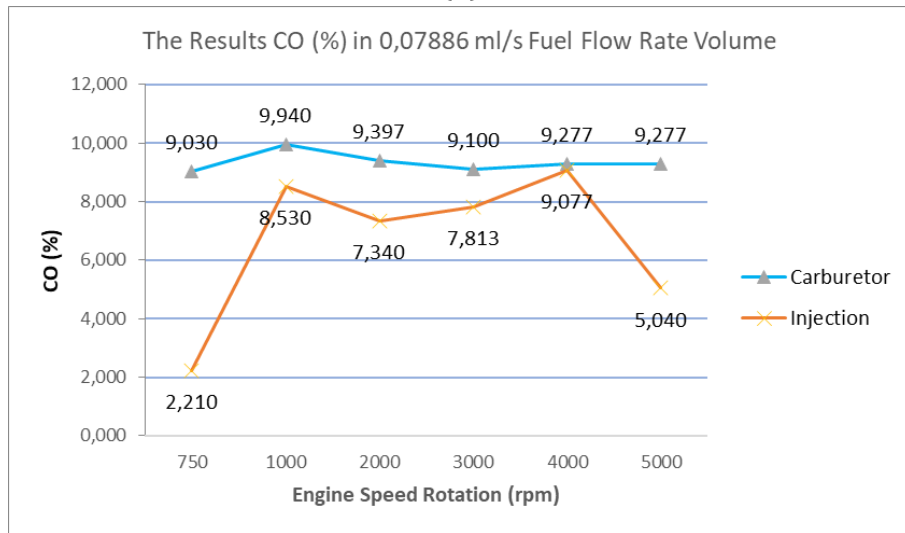

(c)

Based on diagram figure 9, the highest value of carburetor intake manifold has occur when fuel flow rate volume 0,0640 ml/s, the highest value is 9,940 % CO at 2000 rpm and the lowest value is 4,377 % CO at 5000 rpm in the same fuel flow rate volume. When the redesign injection intake manifold highest value is 8,740 % CO at 5000 rpm in fuel flow rate volume 0,0640 ml/s and the lowest value is 1,427 % at 750 rpm in fuel flow rate volume 0,07886 ml/s.

Figure 10. Type of Intake Manifold and Fuel Flow Rate Volume (a) 0,05642 ml/s, (b) 0,0640 ml/s, (c) 0,07886 ml/s againts HC (ppm) Diagram

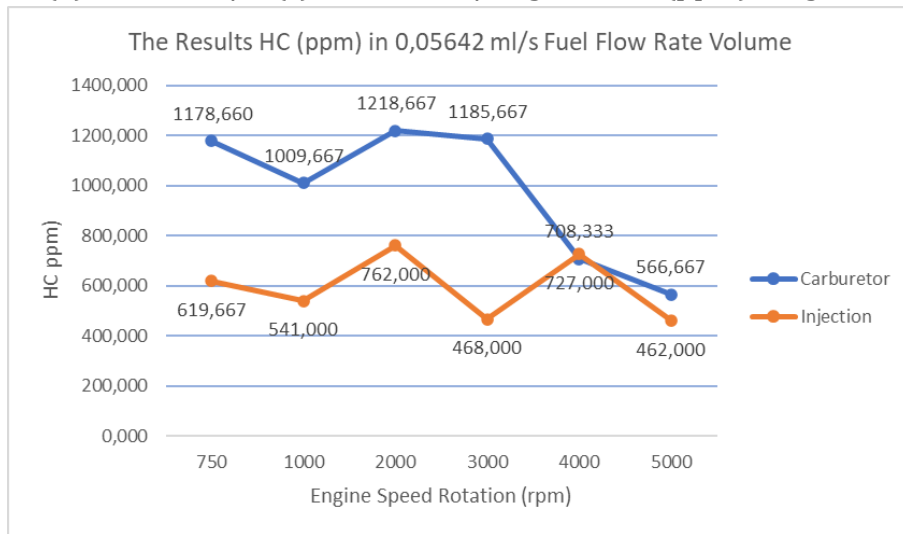

(a)

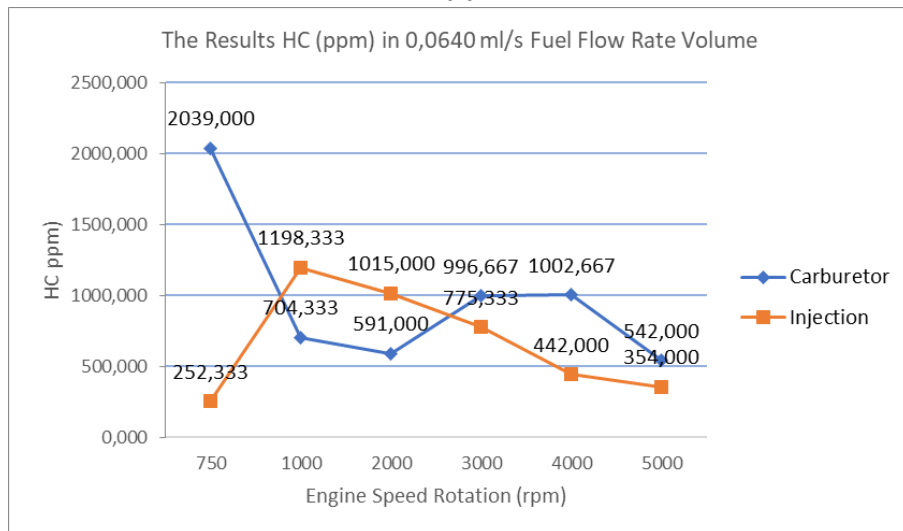

(b)

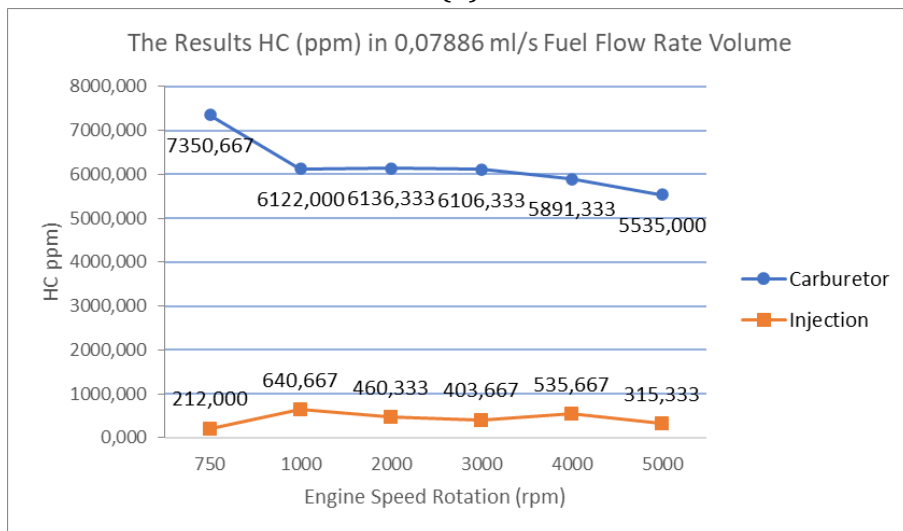

(c)

Figure 10. Shown the result of HC based on diagram, the carburetor intake manifold to generate highest value is 7350 ppm HC at 750 rpm in 0,07886 ml/s fuel flow rate volume and the lowest value is 479 ppm HC at 5000 rpm in 0,0640 ml/s. Redesign injection intake manifold to generate highest value is 1198 33 ppm HC at 1000 rpm in 0,0640 ml/s fuel flow rate volume and the lowest value is 212 ppm HC at 750 rpm in 0,07886 ml/s fuel flow rate volume.

Figure 11. Type of Intake Manifold and Fuel Flow Rate Volume (a) 0,05642 ml/s, (b) 0,0640 ml/s, (c) 0,07886 ml/s againts CO2 (%) Diagram.

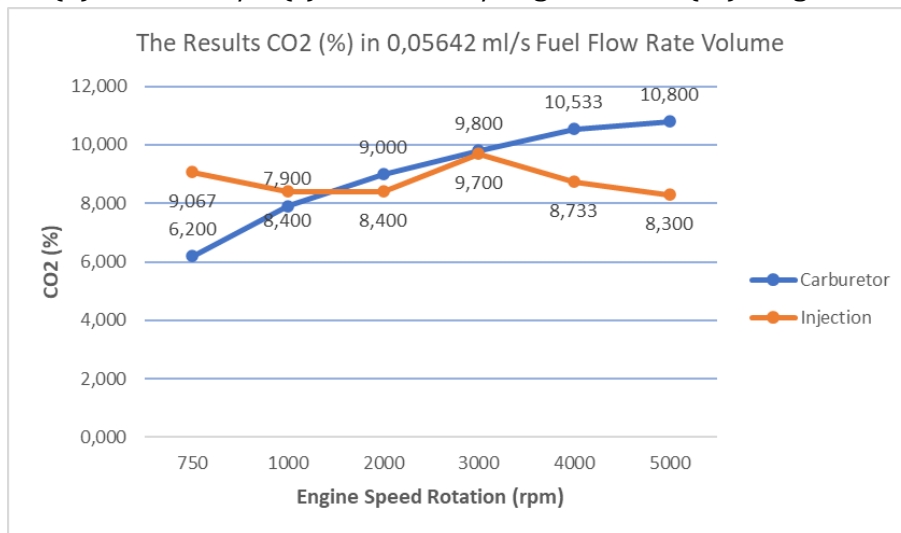

(a)

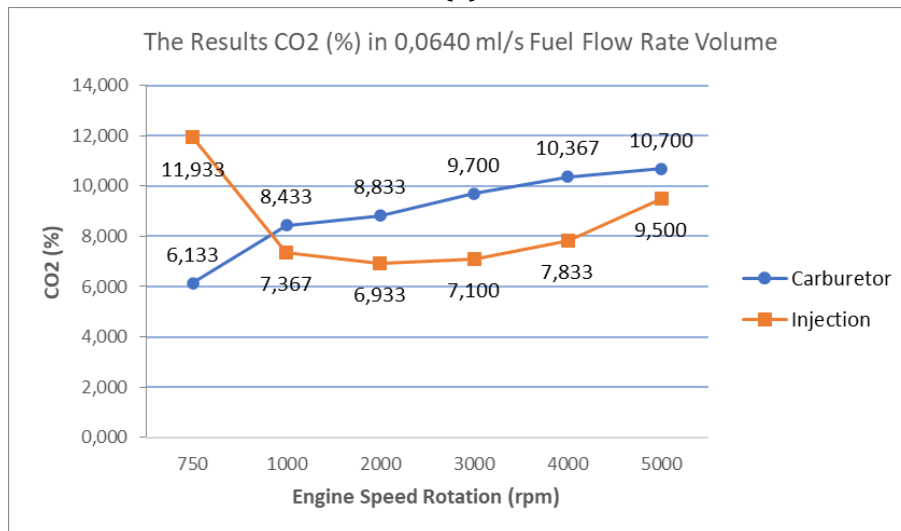

(b)

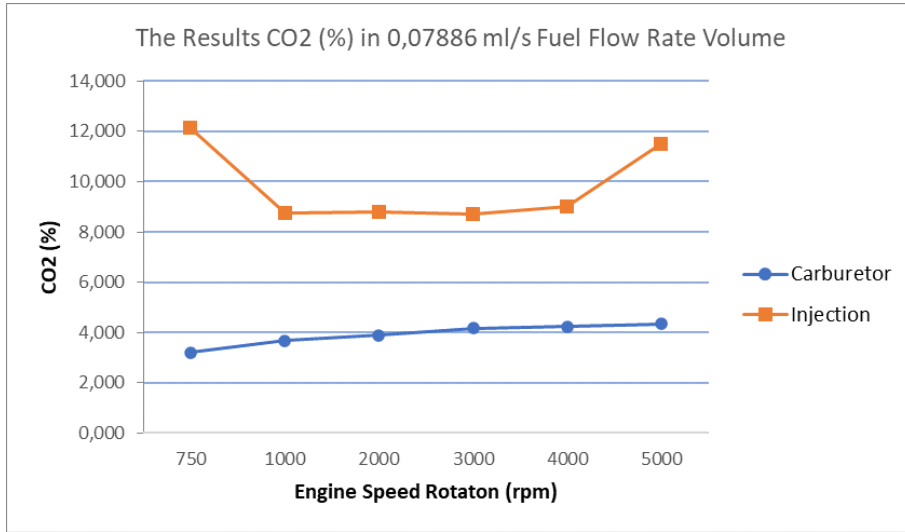

(c)

CO2 resulting from figure 11. The highest value is generated by redesign injection intake manifold 12,133 % CO2 at 750 rpm in fuel flow rate volume and the lowest value is generated by carburator intake manifold 4,617 % CO2 at 750 rpm in the same fuel flow rate volume as shown figure 10.

Figure 12. Type of Intake Manifold and Fuel Flow Rate Volume (a) 0,05642 ml/s, (b) 0,0640 ml/s, (c) 0,07886 ml/s againts O2 (%) Diagram.

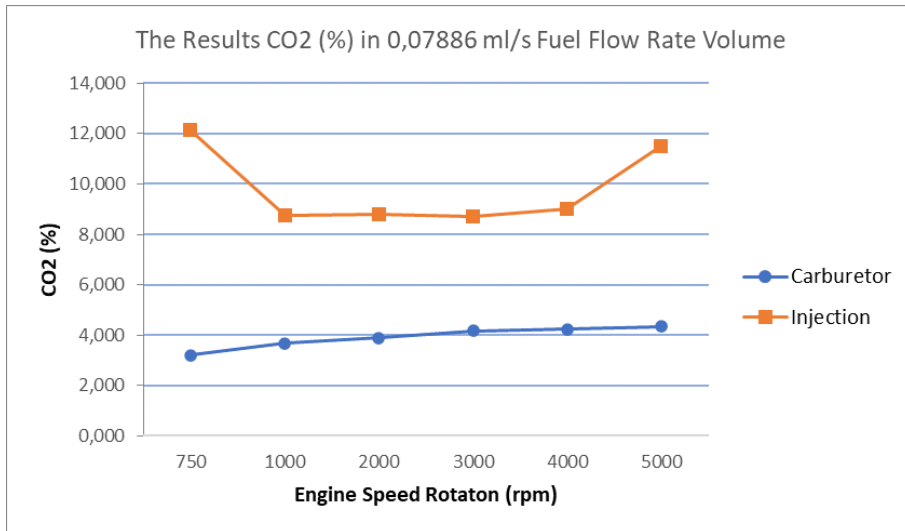

(a)

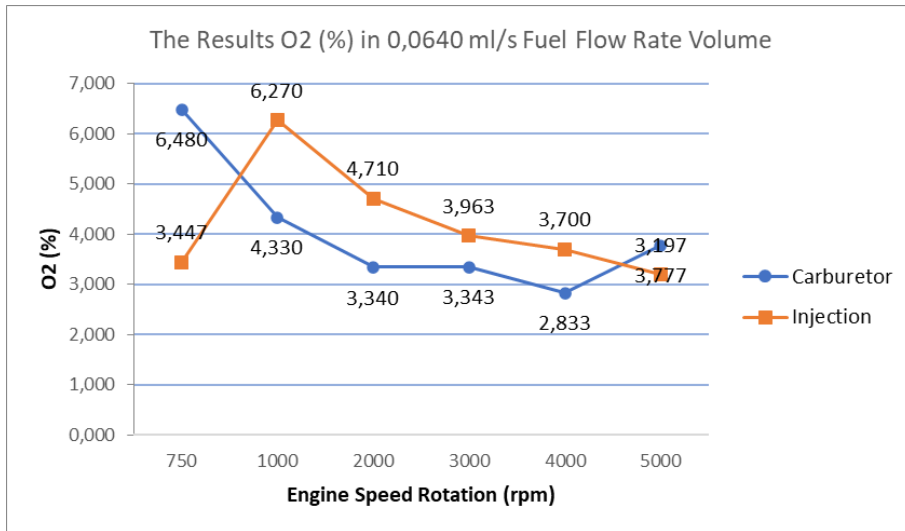

(b)

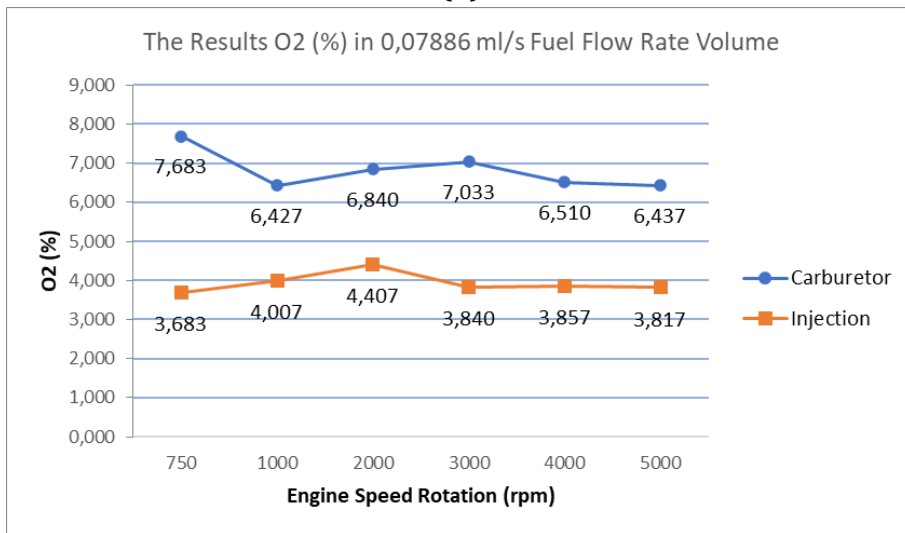

(c)

Figure 12. shown the O2 result. The highest value O2 generated by carburetor intake manifold 7,683 % O2 at 750 rpm in 0,07886 ml/s fuel flow rate volume and the lowest value is 1,767 % O2 with carburetor intake value at 5000 rpm in 0,05642 ml/s fuel flow rate volume.

The result of intake manifold type and fuel flow rate volume againts emissions ready to analysis by two way anova. The experiment is average from three experiment in each variable independent to dependent. The analysis is carried out on each emissions (CO, HC, CO2 and O2).

Figure 13. ANOVA advance test for CO Emission.

Grouping Information Using Fisher LSD Method and 95% Confidence

Jenis Sistem Bahan
Bakar*Volume Laju

Bahan Bakar (ml/s)	N	Mean	Grouping
Redesain 0,07886	6	9,33667	A
Hisap alami 0,06408	6	7,91533	A B
Redesain 0,05642	6	7,71233	A B C
Hisap alami 0,07886	6	6,66833	B C D
Hisap alami 0,05642	6	6,11722	C D
Redesain 0,06408	6	5,97111	D

Means that do not share a letter are significantly different.

Figure 14. ANOVA advance test for HC Emission.

Grouping Information Using Fisher LSD Method and 95% Confidence

Jenis Sistem Bahan
Bakar*Volume Laju

Bahan Bakar (ml/s)	N	Mean	Grouping
Hisap alami 0,07886	6	6190,28	A
Hisap alami 0,06408	6	979,28	B
Hisap alami 0,05642	6	977,94	B
Redesain 0,06408	6	672,83	B C
Redesain 0,05642	6	596,61	B C
Redesain 0,07886	6	427,94	C

Means that do not share a letter are significantly different.

Figure 15. ANOVA advance test for CO2 Emission.

Grouping Information Using Fisher LSD Method and 95% Confidence

Jenis Sistem Bahan
Bakar*Volume Laju

Bahan Bakar (ml/s)	N	Mean	Grouping
Redesain 0,07886	6	9,81667	A
Hisap alami 0,05642	6	9,03889	A B
Hisap alami 0,06408	6	9,02778	A B
Redesain 0,05642	6	8,76667	A B
Redesain 0,06408	6	8,44444	B
Hisap alami 0,07886	6	3,91667	C

Means that do not share a letter are significantly different.

Figure 16. ANOVA advance test for O2 Emission.

Grouping Information Using Fisher LSD Method and 95% Confidence

Jenis Sistem Bahan
Bakar*Volume Laju

Bahan Bakar (ml/s)	N	Mean	Grouping
Hisap alami 0,07886	6	6,82167	A
Redesain 0,06408	6	4,21444	B
Hisap alami 0,06408	6	4,01722	B
Hisap alami 0,05642	6	3,95278	B
Redesain 0,07886	6	3,93500	B
Redesain 0,05642	6	3,69278	B

Means that do not share a letter are significantly different.

By the analysis ANOVA, figure 13 shown the effect of intake manifold type and fuel flow rate volume on CO, the highest average result is the redesign injection intake manifold with 0,07886 ml/s fuel flow rate volume of 9.3367% CO.

Figure 14 shown the highest average result of HC is carburetor intake manifold at 0,07886 ml/s fuel flow rate volume with value 6190,28 ppm HC. Figure 15 shown average highest CO₂ generated by redesign injection intake manifold at 0,7886 ml/s fuel flow rate volume with value 9,81667 % CO₂. Figure 16 shown average highest O₂ generated by carburetor intake manifold at 0,07886 ml/s fuel flow rate volume with value 6,82167 % O₂. The electronic systems of redesign injection manifold can be reduced emissions, when the fuel rich or poor. when fuel rich, emissions was producing more HC that can be dangers for humans. When the fuel poor, emissions was producing more more CO. The both of emissions can be overcome by change the natural suction system to redesign injection system.

CONCLUSION

Based on the study of manufacture and analysis injection device 4 stroke engine against emissions, it can be concluded (1) redesign of intake manifold from carburetor to injection system by sand casting with aluminium material is simple method, because the design at the back of intake was added the place for injector to fuel injection, (2) installation of injection intake manifold, the beginning part was connected throttle body and the end connected to cylinder head of engine, and the system works with electronics system by using Arduino AT-Mega 2560 as a microcontroller, crankshaft position sensor to detect injection and ignition time, unit sensor (IAT, MAP, TP) for detect air intake and injector for fuel injection, (3) in the advanced ANOVA test, the type of intake manifold carburetor or injection and fuel flow rate volume significant effect to emissions CO, HC, CO₂ and O₂.

REFERENCES

- [1] Chun-ming, HU. 2011. Experimental Study of Mixture Formation DISI Engine. Changchun China: International Conference on Transportation, Mechanical, and Electrical Engineering (TMEE) 978-1-4577-1701-7/11/\$26.00 2011 IEEE.
- [2] Daryanto. 2014. Buku Bagaimana Mobil Bekerja. Bandung: ALFABETA.
- [3] Duffy, James E. 1989. Auto Electricity, Electronics, Computers. Illinois, South Holland: The Goodheart-Willcox Company, INC.
- [4] Hidayat, Wahyu. 2012. Motor Bensin Modern. Jakarta: PT Rineka Cipta.
- [5] Irawan, Bambang. 2017. Perhitungan Energi Bahan Bakar di Dalam Silinder. Prosiding SNTT 2017 – Politeknik Negeri Malang Volume 3 – ISSN: 2476-9983.
- [6] Kadir, Abdul. 2017. Pemrograman Arduino dan Android Menggunakan App Inventor. Jakarta: PT Elex Media Komputindo.
- [7] Kunjam, Ram Kumar dkk. 2015. A Study on advance Electronic Fuel Injection System. International Journal of Scientific Research and Management (IJSRM) e-ISSN: 2321-3418 Vol. 3/3608-3613/2015.

- [8] Liu Z. Guo X. Zuo C. Xing H. 2011. Measurement and Analysis on Emissions from an EFI Gasoline Engine under Transient Conditions. New York: Institute Electrical and Electronic Engineering Journal DOI 10.1109/ICDMA.2011.179 IEEE.
- [9] Mohsin, M H dkk. 2014. An Efficient Carburetor Designe using Electronic Fuel Injection for Small Vehicles based on 110 cc self start 4 stroke engine. International Standard Book Number (ISBN): 978-4799-5754-514/\$26.00 2014 IEEE.
- [10] Priyastama, Romie. 2017. Buku Sakti Kuasai SPSS Pengolahan Data & Analisis Data. Yogyakarta: Start Up Pt Anak Hebat Indonesia.
- [11] Sugiharto, Toto. 2009. Analisis Varians. Jakarta: Universitas Gunadarma Fakultas Ekonomi.
- [12] Toyota. 2003. 25 Electronic Control Unit. U.S.A: Toyota Technical Description Manual.
- [13] Toyota. 2003. 42 Fuel Sistem. U.S.A: Toyota Technical Description Manual.
- [14] Toyota. 2003. 43 Injection Duration. U.S.A: Toyota Technical Description Manual.
- [15] Wang T. Lin X. 2010. Research in Fuel Injection Revision Control of Gasoline Engine based on the Electronic Throttle during Transient Condition. International Conference on Computer, Mechatronics, Control and Electronic Engineering (CMCE) 978-1-4244-7956-6/10/\$26.00 2010 IEEE.
- [16] Winoko, Yuniarto A. 2017. Buku Pengujian Daya dan Emisi Gas Buang. Malang: POLINEMA PRESS.
- [17] Xubing D. Xiaofeng L. 2011. Control Strategy & Calibration of Fuel Injection Impulse Width on EFI Motorcycle Engine. New York: Institute of Electrical and Eelctronic Engineering 978-1-4244-8039-5/11/\$26.00 2011 IEEE.
- [18] Sim, H S dan Chung S H. 2002. Comparison of Hydrocarbon Reduction in A SI Engine Between Continuous and Synchronized Secondary Air Injection. Seoul: International Journal of Automotive Technology, Vol. 3, No. 1, pp. 41-46 (2002).
- [19] Xu BY, Liang FY, Cai SL dan Qi YL. 2005. Numerical Analysis of Fuel Injection in Intake Manifold and Intake Process of A MPI Natural Gas Engine. China: International Journal of Automotive Technology, Vol. 6, No. 6, pp, 579-584 (2005).
- [20] Kono T, Miyata H, Uraki M dan Yamazaki R. 2006. Research on Ultra Low Emission for Large Displacement Motorcycles. Japan: International of Automotive Technologi, Vol 7, No. 3 pp. 277-282 (2006).
- [21] Kadir, Abdul. 2017. Buku Pemrograman Arduino & Android menggunakan App Inventor. Jakarta: PT Elex Media Komputindo.
- [22] Toyota. 2003. 24 34 EFI & Sensor. U.S.A: Toyota Technical Description Manual.

- [23] Toyota. 2003. 33 Position Sensor. U.S.A: Toyota Technical Description Manual.
- [24] Toyota. 2003. 36 Speed & Position Sensor. U.S.A: Toyota Technical Description Manual.
- [25] Satishkumar K., Soundararajan R., Dinesh G. dan Surjith S. Design and Air Flow in Intake Manifold with Different Cross Section Using CFD. International Journal of Innovative Technology and Exploring Engineering (IJITEE), ISSN; 2278-3075 Vol. 8 No. 4 (2019).
- [26] Hushim Mohd Faisal, Alimin Ahmad Jais, Razali Mohd Azahari, Mohammed Akmal Nizam, Sapit Azwan dan Carvajal Julio Cesar Mendez. Air Flow Behaviour Different Intake Manifold Angles for Small 4-Stroke PFI Retrofit KIT System. Asian Research Publishing Network, ISSN 1819-6608 VOL. 11, No. 12 (2016).
- [27] Arsah, A Mohammad dkk. Improvement of a Lighweigtht Alumunium Cylinder Block Design Using Finite Element Stress Analysis. International Journal of Integrated Engineering Vol. 12 No. 5, ISSN : 2229-838X (2020).
- [28] Vas, Juliano dkk. Design and Manufacture of a formula SAE Variable Intake Manifold. SAE International Journal 2017-36-0181 (2017).
- [29] Ren, Huanhuan dkk. Simulation Study of Injection Strategy on the Emission in Automotive Engine. China Automotive Technology and Research Center. IOP Publishing, Series: Earth And Environmental Science 252 032143 (2019).
- [30] Hadi, Syamsul. 2016. Teknologi Bahan. Yogyakarta: Pemerbit CV ANDI OFFSET

Copyright Holder :

© Bagus Dwi Cahyo, Bambang Irawan (2024)

First Publication Right :

© Asian Journal Science and Engineering

This article is under:

CC BY SA